



Applications

- Power stations, general industry, process engineering
- For water, steam, gas, oil & other non-aggressive media
- Further applications on request

Operating Data

- Pressure up to 439 bar (6250 PSI)
- Temperature up to +593°C/1100°F
- Pressure-temperature ratings as per ASME B 16.34, Special class

Materials

ANSI Special class (as per ASME B 16.34)

- # 900/1500/2500 - A 216 WCB from 0°C to 425°C
- # 900/1500/2500 - A 217 WC6/WC9 from 0°C to 425°C
- # Other materials on request

Design

- As per ASME B 16.34
- Pressure Seal Bonnet Design
- Stellite hard-faced Seats & Disc surface
- Graphite gaskets & packings with Braided wiping rings
- Direct retrofitting of Actuator

Variants on Request

- By-pass execution
- Actuator execution / Gear Box execution
- Position indicator
- Locking arrangement
- Other materials
- Other executions

Remarks

Pressure Seal Gate valve leaflet no. : 0501.10/01 - 18 G3
Pressure Seal Check valve leaflet no. : 0503.10/01 - 18 G3
Operating instructions no. : 0500.80/01 - 18 G3

On all enquiries / orders please specify :

- | | |
|--------------------------|-----------------------------|
| 1. Type | 7. Material of construction |
| 2. ANSI Pressure class | 8. Flow medium |
| 3. Size | 9. Type of end connection |
| 4. Design pressure | 10. Pipe schedule |
| 5. Operating pressure | 11. Variants |
| 6. Differential pressure | 12. Leaflet no. |

When ordering spares; indicate valve serial number & year of manufacture.

- Valves meets ASME 16.34 Special class requirements
- Compact yoke design ensures low valve weight
- Designed to retrofit valve with Actuator at site without disassembly of pressure retaining parts
- Stem lock arrangement ensures non-rotation of stem
- 'Y' Pattern body minimizes pressure drop

Flow Seal

- Fully stellite body seat & disc seat
- Seat rings - seal welded to body
- Valve sizes 6" and above will be reverse flow design to ensure leak tightness at full differential pressure

Disc Design

- Disc designed to reduce pressure drop across the valve
- Stellite-6 hard faced seating surface enhances sealing life

Stem Disc Connection

- Stem-disc joint capable of withstanding vibration during valve opening

Gland Seal

- Die moulded graphite rings ensures effective sealing to atmosphere
- Top & bottom rings are braided graphite
- Braided rings offer smooth wiping action thereby arresting graphite depletion
- Smooth finished & polished stem and smooth stuffing box surfaces improve gland sealing life
- Two piece self aligning gland bolting arrangement
- Integral hard faced back seat for maximum service life

Pressure Seal Bonnet

- Die moulded graphite gasket
- Segmental ring arrangement with knock-out hole ensures easy disassembly

Retrofitting of Actuator

Mount Actuator with non-thrust base. Type 'E' or 'B' after removing handwheel.

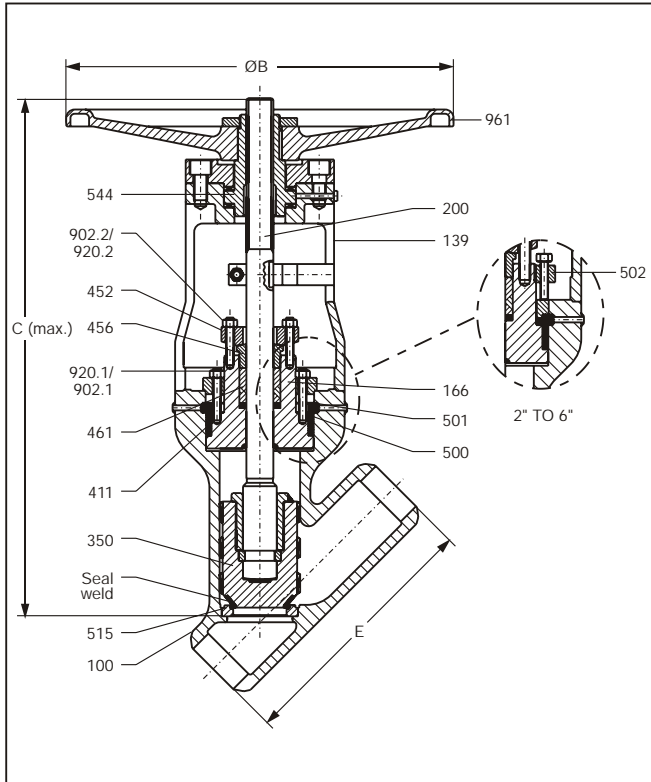

Dimensions

Class 900		2"	3"	4"	6"	8"
E	Inch	14.5	12.0	14.0	20.0	26.0
	mm	368.3	304.8	355.6	508.0	660.4
ØB*	Inch	1.9	2.9	3.6	5.5	7.2
	mm	48.0	73.5	92.0	140.0	182.5
C _(max.)	Inch	20.7	26.5	29.0	37.6	40.8
	mm	525.0	673.0	737.0	955.0	1037.0
ØD	Inch	14.0	18.0	20.0	20.0	20.0
	mm	356.0	457.0	508.0	508.0	508.0

* Schedule 80 up to 3". Schedule 120 for 4" and above. Alternate schedule on request.

Class 1500		2"	3"	4"	6"
E	Inch	14.6	18.5	16.0	27.8
	mm	369.8	469.9	406.4	706.4
ØB*	Inch	1.7	2.6	3.4	5.2
	mm	43.0	66.5	87.5	132.0
C _(max.)	Inch	28.0	28.9	39.2	42.1
	mm	712.0	735.0	995.0	1070.0
ØD	Inch	14.0	20.0	20.0	24.0
	mm	356.0	508.0	508.0	610

* Schedule 160. Alternate schedule on request.

Class 2500		2"	3"	4"	6"
E	Inch	17.8	14.5	26.5	36.0
	mm	451.0	368.3	673.1	914.4
ØB*	Inch	1.5	2.3	3.2	4.9
	mm	38.0	58.5	80.0	124.5
C _(max.)	Inch	28.1	30.5	34.4	50.3
	mm	713.0	775.0	875.0	1277.0
ØD	Inch	14.0	18.0	20.0	24.0
	mm	356.0	457.0	508.0	610.0

* Schedule XXS. Alternate schedule on request.

Design Specifications

- General valve design & pressure, temperature rating : ASME B 16.34 Special class
- Butt weld end design : ASME B 16.25
- End to end dimension : ASME B 16.10
- Testing : API 598
- ASME B 16.34 Section 8

Materials

Part No.	Description	Material		
100	Body	A 216-WCB	A 217-WC9	A 217-WC6
139	Yoke	A 216-WCB	A 216-WCB	A 216-WCB
166	* Bonnet	A 216-WCB+ST6	A 217-WC9+ST6	A 217-WC6+ST6
200	Stem	A 479-410-2	A 479-410-2	A 479-410-2
350	Disc	A 216-WCB-ST6	A 217-WC9+ST6	A 217-WC6+ST6
411	Gasket	Graphite	Graphite	Graphite
452	Gland Flange	A 216-WCB	A 216-WCB	A 216-WCB
456	Gland Bush	A 276-410	A 276-410	A 276-410
461	Gland Packing	Graphite	Graphite	Graphite
500	Spacer Ring	A 217-CA15	A 217-CA15	A 217-CA15
501	Thrust Ring	A 182-F22	A 182-F22	A 182-F22
502	Retaining Plate	IS 2062	IS 2062	IS 2062
515	Seat Ring	A 216-WCB+ST6	A 217-WC9+ST6	A 217-WC6+ST6
544	Stem Nut	Al. Bronze	Al. Bronze	Al. Bronze
902.1/902.2	Stud	A 193-B7	A 193-B16	A 193-B16
920.1/920.2	Hex. Nut	A 194-2H	A 194-4	A 194-4
961	Handwheel	SG 400/12	SG 400/12	SG 400/12

* Integral Bonnet back seat ST6 (HF)

Test Specifications

Test / Test pressure	#900		#1500		#2500		Testing medium
	kg/cm ²	PSI	kg/cm ²	PSI	kg/cm ²	PSI	
Shell	238	3375	396	5625	660	9375	Water
Back seat	174	2475	291	4125	484	6875	
Seat leak	174	2475	291	4125	484	6875	

Material : A 216 WCB
Table A : Special Class

Temperature		#900		#1500		#2500	
°F	°C	PSI	kg/cm ²	PSI	kg/cm ²	PSI	kg/cm ²
-20 to100	-17 to 38	2250	158.2	3750	263.7	6250	439.4
200	93.3						
300	148.9						
400	204.4						
500	260.0						
600	315.6	2140	150.5	3565	250.7	5940	417.6
650	343.3	2100	147.6	3495	245.7	5825	409.6
700	371.1	2080	146.2	3470	244.0	5780	406.4
750	398.9	1890	132.9	3150	221.5	5250	369.1
800	426.7	1545	108.6	2570	180.7	4285	301.3
850	454.4	1005	70.7	1670	117.4	2785	195.8
900	482.2	645	45.3	1070	75.2	1785	125.5
950	510.0	385	27.1	645	45.3	1070	75.2
1000	537.8	195	13.7	320	22.5	535	37.6

Material : A 352 LCB
Table B : Special Class

Temperature		#900		#1500		#2500	
°F	°C	PSI	kg/cm ²	PSI	kg/cm ²	PSI	kg/cm ²
-20 to100	-17 to 38	2085	146.5	3470	244.0	5785	406.7
200	93.3						
300	148.9						
400	204.4						
500	260.0						
600	315.6	2040	143.4	3400	239.0	5670	398.7
650	343.3	1995	140.2	3320	233.4	5535	389.2
700	371.1	1775	124.8	2960	208.1	4930	346.6
750	398.9	1465	103.0	2455	172.6	4070	286.2
800	426.7	1005	70.6	1670	117.4	2785	195.8
850	454.4	645	45.3	1070	75.2	1785	125.5
900	482.2	385	27.1	645	45.3	1070	75.2
950	510.0	195	13.7	320	22.5	535	37.6

Material : A 217 WC6
Table C : Special Class

Temperature		#900		#1500		#2500	
°F	°C	PSI	kg/cm ²	PSI	kg/cm ²	PSI	kg/cm ²
-20 to100	-17 to 38	2250	158.1	3750	263.7	6250	439.4
200	93.3						
300	148.9						
400	204.4						
500	260.0						
600	315.6						
650	343.3						
700	371.1	2200	154.6	3665	257.7	6110	429.6
750	398.9	2185	153.5	3645	256.3	6070	426.8
800	426.7	2160	151.8	3600	253.1	6000	421.9
850	454.4	2030	142.7	3385	238.0	5645	396.9
900	482.2	1760	123.7	2935	206.4	4895	344.2
950	510.0	1195	84.0	1995	140.3	3320	233.4
1000	537.8	810	56.9	1350	94.9	2250	158.2
1050	565.6	540	37.9	900	63.3	1500	105.5
1100	593.3	360	25.3	600	42.2	1000	70.3
1150	621.1	230	16.2	385	27.1	645	45.3
1200	648.9	140	9.8	235	16.5	395	27.8

Material : A 217 WC9
Table D : Special Class

Temperature		#900		#1500		#2500	
°F	°C	PSI	kg/cm ²	PSI	kg/cm ²	PSI	kg/cm ²
-20 to100	-17 to 38	2250	158.1	3750	263.7	6250	439.4
200	93.3	2250	158.1	3750	263.7	6250	439.4
300	148.9	2225	156.4	3705	260.5	6180	434.5
400	204.4	2175	152.8	3620	254.5	6035	424.3
500	260.0	2160	151.8	3600	253.1	6000	421.9
600	315.6	2160	158.1	3600	253.1	6000	421.9
650	343.3	2145	150.7	3580	251.7	5965	419.4
700	371.1	2135	150.0	3555	249.9	5930	416.9
750	398.9	2070	145.5	3450	242.6	5750	404.3
800	426.7	2020	142.0	3365	236.6	5605	394.1
850	454.4	1930	135.6	3215	226.0	5355	376.5
900	482.2	1800	126.5	3000	210.9	5000	351.6
950	510.0	1415	99.4	2355	165.9	3930	276.3
1000	537.8	975	68.5	1630	114.6	2715	190.9
1050	565.6	655	46.0	1095	77.0	1820	128.0
1100	593.3	410	28.8	685	48.2	1145	80.5
1150	621.1	255	17.9	430	30.2	715	50.3
1200	648.9	155	10.9	255	17.9	430	30.2

